



VCom[®] Inc.

www.vcom.com

Advanced Broadband Products

DESCRIPTION

5.7 GHz

BROADBAND WIRELESS

INTERNET NETWORK

USING BTR5857

BWIN[™] BASED ON DOCSIS[™]



1 EXECUTIVE SUMMARY

VCom Inc. is pleased to present you with this summary description of a typical Broadband Wireless Internet Network based on proven Data over Cable Service Interface Specifications (DOCSIS™) technology. Our Broadband Wireless Internet Network, **BWIN™ BASED ON DOCSIS™** proposal marries DOCSIS Cable Modem Termination Systems (CMTS) with VCom radio frequency (RF) technology. Commercial deployments have demonstrated that the **BWIN™ BASED ON DOCSIS™** approach achieves high performance and reliability in a cost-effective fashion.

VCom designs and supplies leading edge broadband access transmission equipment, primarily for broadband fixed wireless networks and data over cable. Service providers use VCom's products to deliver high-speed data, Internet, video on demand (VOD) and other bandwidth intensive services to residential and business subscribers. VCom's products are designed to allow service providers to rapidly and cost-effectively bridge the last mile, by overcoming the bottleneck resulting from insufficient bandwidth existing in legacy last mile infrastructures. The Company's customer base includes original equipment manufacturers (OEM), system integrators and leading multiple system operators (MSO) and other service providers. Please find details at <http://www.vcom.com/>.

The key feature of VCom's **BWIN™ BASED ON DOCSIS™** solution is that high volumes of standard DOCSIS™ modems are being produced by a large number of manufacturers; the economies of scale created by this situation results in inexpensive, feature rich subscriber equipment. The basic most cost-effective network is designed with only a limited amount of redundancy. Options are available that provide full 1 to 1 redundancy for all CMTS and base station RF equipment.

2 SYSTEM OVERVIEW

The architecture of the VCom **BWIN™ BASED ON DOCSIS™** system utilizes standard DOCSIS™ cable equipment as the network elements. Complementing this standard DOCSIS™ setup is VCom RF hardware designed to translate specific sub-bands of the DOCSIS™ cable frequency plan into the frequency allocations of each specific customer.

Key characteristics of the system are as follows:

- 27 Mbps time division multiplexed downstream using 64QAM in a 6 MHz channel, or 36 Mbps in an 8 MHz channel
- 256 Kbps to 10 Mbps time division multiple access burst upstream using QPSK or 16QAM in 200 kHz to 3.2 MHz bandwidths
- near line of sight performance
- systems already operating at 600 MHz, 700 MHz, 1.9 GHz, 2.1 GHz, 2.3 GHz, 2.5 GHz, 3.5 GHz and 5.7 GHz around the world
- audible installation alignment beeper available on some models to facilitate customer self-install and avoid a truck roll
- economies of scale by reusing existing DOCSIS™ products which are now being deployed in high volume worldwide



2.1 DOCSIS Overview

DOCSIS™ is an open industry standard developed and coordinated through the efforts of cable MSOs and technology manufacturers such as Cisco, Motorola, Arris etc. and VCom under the non-profit institution, CableLabs®. DOCSIS™ technology is mature and in operation in many countries around the world as the standard for Internet access on hybrid fibre coax cable systems. A fundamental advantage of using DOCSIS™ is the wide variety of manufacturers producing cable modems and the volumes currently being deployed which translate into very cost effective subscriber equipment. Over 15 million DOCSIS™ cable modems are currently deployed worldwide with over 200,000 upstream DOCSIS™ ports. DOCSIS™ cable modem pricing is now less than US\$55 in quantity.

The technology behind DOCSIS™ also lends itself very well to use as a fixed broadband wireless access mechanism. A well-developed physical layer, sophisticated media access control, and a complete network reference model provide for a commercial grade wireless system.

A quick overview of features is given below, but a more thorough discussion on the specific technical requirements for wireless can be provided as your project matures. CableLabs® website, <http://www.cablemodem.com/> also contains the current DOCSIS™ specifications.

2.1.1 Physical Layer Characteristics

Key parameters of the physical layer include:

Downstream:

- 30 Mbps in a 6 MHz RF channel (standard DOCSIS™)
- 64QAM modulation
- Reed-Solomon forward error correction (~10% overhead)
- time division multiplexing
- continuous transmission

Upstream:

- variable channel bandwidths from 200 KHz to 3.2 MHz
- QPSK or 16QAM modulation
- Reed-Solomon forward error correction (~10% overhead)
- burst mode transmission
- adaptive power control over 50 dB range

2.1.2 Media Access Control (MAC)

The DOCSIS™ MAC utilizes a request/grant mechanism under central management of the CMTS. This time division multiple access (TDMA) reservation-based protocol requires each CPE to request a time to transmit data. The CMTS examines all of the incoming requests and grants a time to transmit based on a multitude of parameters including CPE data rate limitations and service priorities. A DOCSIS™ 1.1 compliant system with full QoS features is also available.



2.1.3 Security

Baseline Privacy Plus (BPI+), included as part of the DOCSIS™ protocol, provides advanced security and privacy features for both the service provider and the customer. All over-the-air communications operate with 56-bit DES encryption (or 40 bit where regulations require). Additionally, encrypted key management between the CMTS and modems requires subscriber authorization and registration to ensure reliable and secure billing for multiple server classes which prevents unauthorized access to the system. Various cable modems support end to end 3DES encryption.

2.2 RF Systems

2.2.1 Point to Multipoint Configuration

Figure 1 shows the overall system diagram for point to multipoint communication. A generic diagram of a single sector system is shown but standard configurations allow for one, three, four and six sector base stations. Detailed network capacity and RF planning is necessary to determine the optimum solution for a specific customer requirement.

Since the amount of spectrum generally available in the 5.8 GHz band is 100 MHz, the frequency plan in Table 1 has been chosen to maximize overall capacity and work with the standard 6 MHz downstream channels. An individual system can use both A and B bands for full frequency utilization.

Band Designator	Frequency
Upstream (Low Band)	5727-5751 MHz
Upstream (High Band)	5751-5775 MHz
Downstream (Low Band)	5775-5799 MHz
Downstream (High Band)	5799-5823 MHz

Table 1 - 5.7 GHz Frequency Plan



FIGURE 1 - POINT TO MULTIPOINT SYSTEM OVERVIEW

VCom Inc.

www.vcom.com

Advanced Broadband Products

Voice: (306) 955-7075

Fax: (306) 955-9919

Email: sales@vcom.com

Web: www.vcom.com

**Transceiver Reverse Path Output
TRI5758 → +28 dBm EIRP (Integrated Antenna)**

Reach farther and capture more subscribers

Automatic Transmit RF Mute

Reduces power consumption and virtually eliminates broadband noise emissions

Compact, Very Easy to Install

Unique audible alignment beeper on some models to facilitate self-install



**VCom
TRI5758
Transceiver**

**Subscriber
Home / Office**



Downstream
5775 to 5799 MHz (Low Band)
5799 to 5823 MHz (High Band)
(27 Mbps)

Upstream
5727 to 5751 MHz (Low Band)
5751 to 5775 MHz (High Band)
(256 kbps to 10 Mbps)

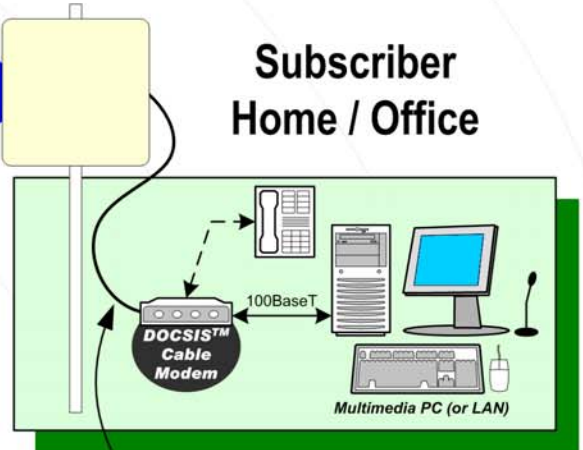

DOCSIS™ cable modem frequencies

Full DOCSIS™ speeds

No limitation due to wireless link

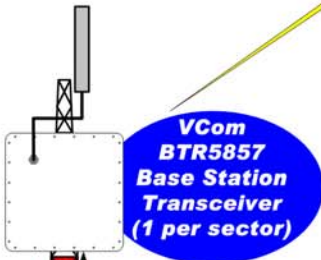

Base Station

Distances Up to 16 km

Depends on geography and tower height

Economic Network Extension

Low cost approach to extending broadband access to areas in the vicinity of, but not covered by, existing cable infrastructure

Utilizes Non-Proprietary DOCSIS™ equipment

Low cost, mature industry proven performance and quicker ROI

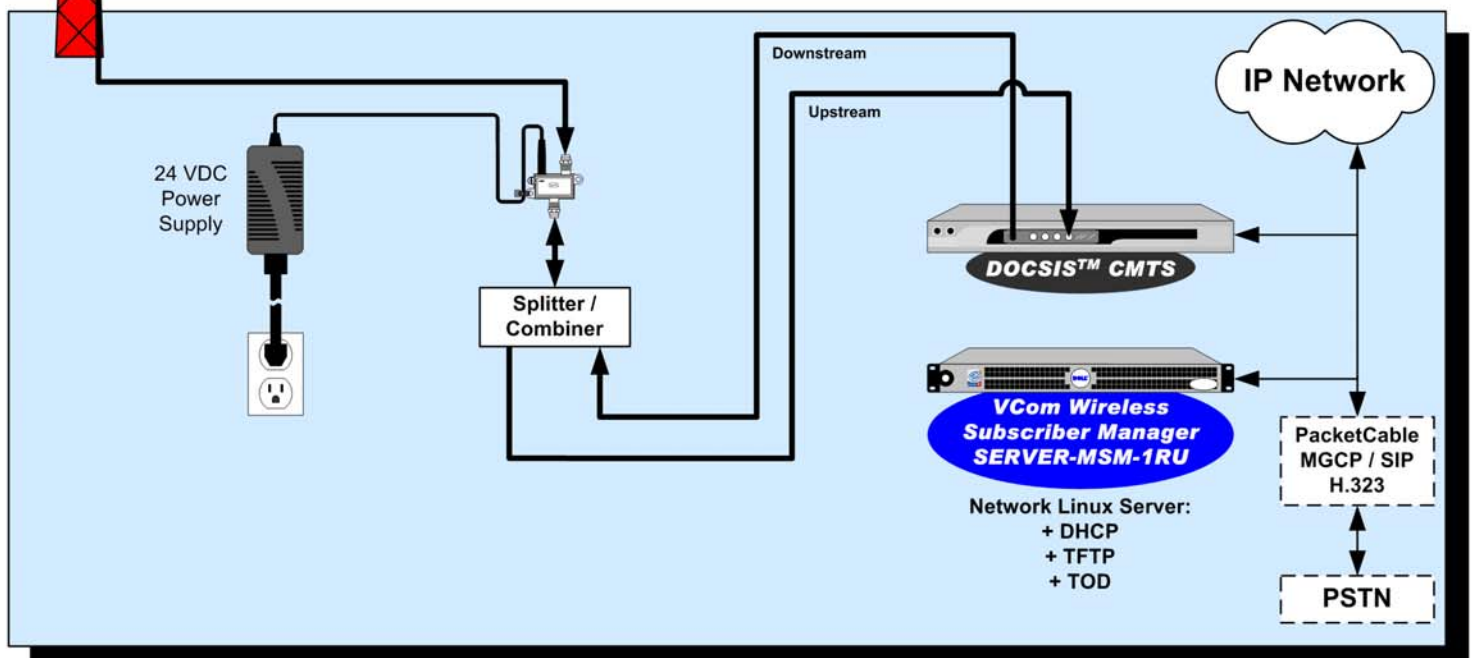

Network Linux Server:
+ DHCP
+ TFTP
+ TOD



2.2.1.1 BTR5857 Base Station

Figure 2 shows a detailed diagram of the standard BTR5857 base station configuration; the transport/network connection ties directly into the hub CMTS. **BWIN™ BASED ON DOCSIS™** capability at 5.7 GHz requires a BTR5857 to complement the CMTS at the base station (hub) site. The BTR5857 serves to convert the standard DOCSIS™ cable frequency plan to the required 5.8 GHz frequency plan.

The BTR5857 Base Station Transceiver is an outdoor transceiver mounted next to the antenna. Various external single antenna configurations depending on the cell size and subscriber density are available; standard options include omnidirectional, 120°, 90°, and 60°.



VCom Inc.
www.vcom.com
Advanced Broadband Products

Voice: (306) 955-7075
Fax: (306) 955-9919
Email: sales@vcom.com
Web: www.vcom.com

FIGURE 2 - POINT TO MULTIPOINT BASE STATION DETAIL Single Sector

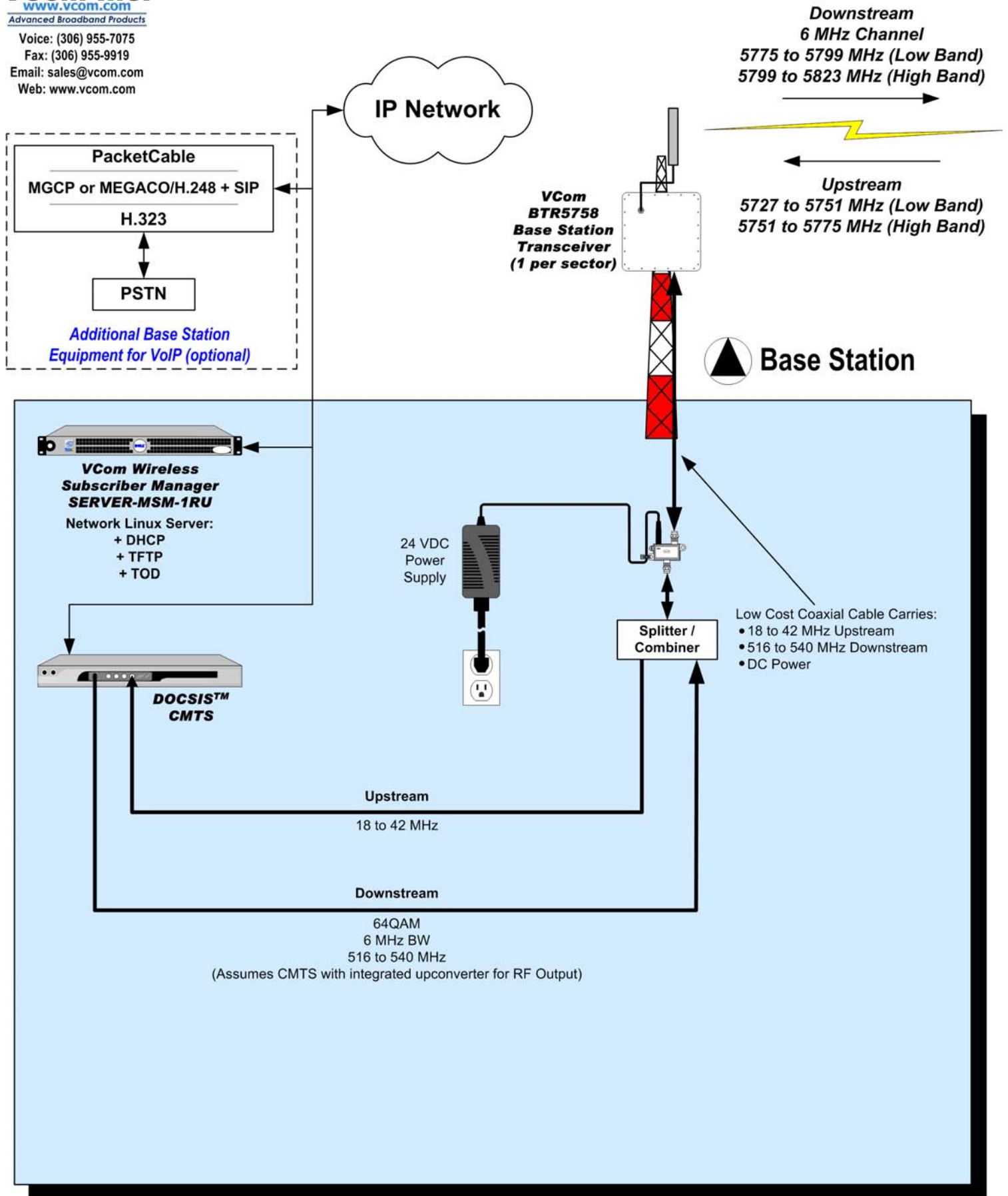



2.2.1.2 Subscriber

Figure 3 details the configuration for a standard subscriber installation. There are two fundamental elements, each with multiple options depending on performance and feature set: the outdoor RF transceiver (TRI5758) and the indoor DOCSIS™ modem.

The TRI5758 subscriber transceiver serves to frequency translate and amplify the upstream and downstream signals to the appropriate cable frequencies for use by the indoor DOCSIS™ modem. A highly directional flat panel antenna is integrated with the transceiver and a single low cost 75 ohm cable (i.e.: RG-59 or RG-6) is used to connect between the transceiver IF port and indoor AC/DC power inserter. A short jumper cable is used to connect to the DOCSIS™ modem. Recommended modems depend on the application.



VCom Inc.
www.vcom.com

Advanced Broadband Products
Voice: (306) 955-7075
Fax: (306) 955-9919
Email: sales@vcom.com
Web: www.vcom.com

FIGURE 3 - POINT TO MULTIPOINT SUBSCRIBER DETAIL Subscriber Home/Office

VCom 5.7 GHz Transceiver Options

Integrated Antenna (flat panel)
TRI5758

Low Band Version (Option S5801):
Downstream 5775 to 5799 MHz
Upstream 5727 to 5751 MHz, +28 dBm EIRP

High Band Version (Option S5802):
Downstream 5799 to 5823 MHz
Upstream 5751 to 5775 MHz, +28 dBm EIRP

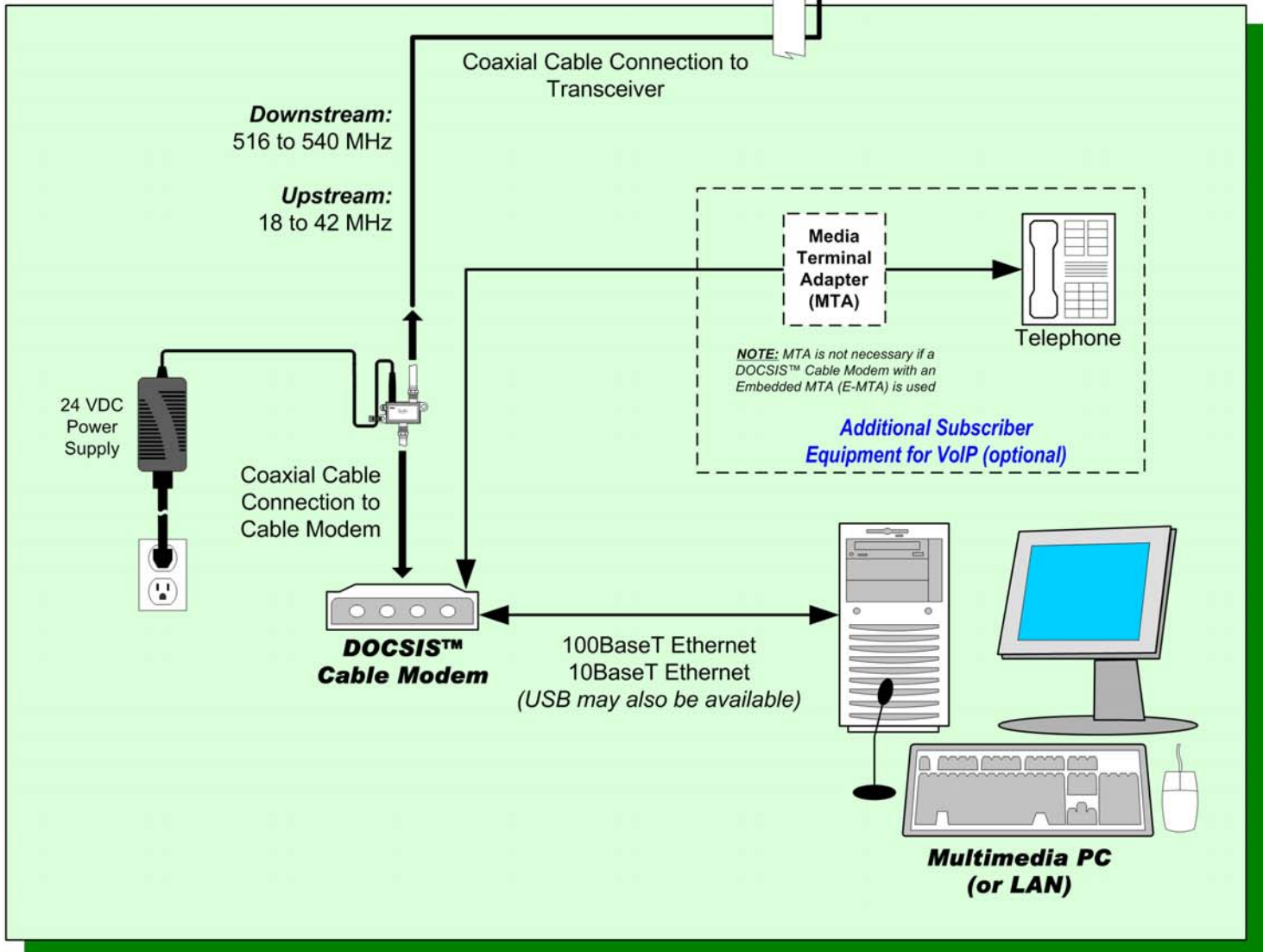
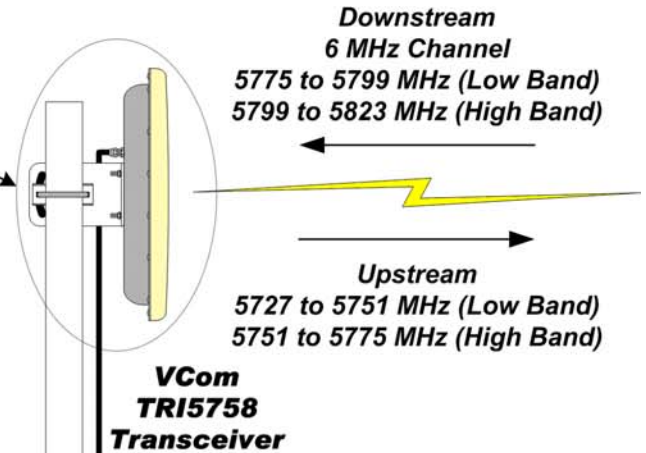



2.3 Element and Network Management

All network and RF elements, with the exception of the subscriber transceivers are fully visible on the network when using a VCom SERVER. VCom's SERVER is a Linux based web-server configured with VCom's Microwave History Manager (MHM) software. The MHM software offers basic logging and display of cable modem statistics.

VCom's optional Microwave Subscriber Manager (MSM) software offers DHCP, TFTP, customer database, individual control of cable modems, and latitude/longitude mapping support functions in addition to the basic functions available in MHM.

3 Ongoing Field Trial

VCom now has 33 different transceiver designs covering frequency bands from 500 MHz to 6 GHz and has sold thousands of CPE units globally. VCom's confidence in these products has lead to a launched a service provisioning (WISP) subsidiary under the name YourLINK (<http://www.yourlink.ca/>) and currently operates in Saskatoon, SK Canada.

References to customers with operational systems on 4 continents are available on request. VCom would be pleased to demonstrate this system and to put in place any particular tests or equipment configurations to demonstrate the performance and manageability of the system.

For more information contact:

VCom Inc.

150 Cardinal Crescent
Saskatoon SK
Canada S7L 6H7
306 955 7075

4210 Commerce Circle
Victoria BC
Canada V8Z 6N6
250 881 1982

[e-mail: sales@vcom.com](mailto:sales@vcom.com)
<http://www.vcom.com>